

ANBAUANLEITUNG

mounting instructions • instructions de montage • instrucciones de montaje • istruzioni di montaggio

NSW.07.602.61000/B

beinhaltet • contains • contient • contiene • contiene

NSW.07.602.10000/B

NSW.00.490.10101

Item number: **NSW.07.602.10000/B**

Revision: **00** · Date: **06 - 2024**

Light mount

 ~ 0.25 h.

EASY  DIFFICULT

ENGLISH Thank you for choosing this premium product from SW-MOTECH. Visit our online shop for more information (e.g. model assignments). Required documents (e.g. national type approval) are available there for you to download.

Please read and understand all the instructions, safety information and warnings in these mounting instructions before mounting and using the product in order to avoid injury and damage. Keep these mounting instructions for reference.

This product was developed for vehicles in factory condition. Compatibility with original accessories or accessories from other manufacturers cannot be guaranteed.

These mounting instructions have been prepared to the best of our current knowledge. No legal claims relating to accuracy can be made. Errors and omissions excepted. We reserve the right to make technical and design changes. The copyright is held by SW-MOTECH.

SAFETY WARNING SYMBOL

 This warning symbol is used in these mounting instructions to warn of deadly dangers, injuries or other hazards. The words **DANGER**, **WARNING** or **CAUTION** are used as part of this warning symbol to convey important safety messages and information relating to the installation and use of this product. These words, together with the safety warning symbol, mean:

 **DANGER:** Indicates a hazardous situation which, if not avoided, will result in death or serious injury!

 **WARNING:** Indicates a hazardous situation which, if not avoided, may result in death or serious injury!

 **CAUTION:** Indicates a hazardous situation which, if not avoided, may result in minor or moderate injury!

 **NOTE:** Important information, but not relating to a risk of death or injury (property damage only)!

GENERAL INFORMATION

 **WARNING:** Assembly and/or maintenance of this product requires advanced technical skill, appropriate tools, and a good understanding of tool usage and torque specifications. For your own safety, SW-MOTECH recommends having the assembly and/or maintenance carried out by a qualified and certified motorcycle workshop.

 **WARNING:** If you do choose to assemble this product yourself, carefully and fully read the mounting instructions before assembly and use, and follow all instructions to avoid serious injury or death. Also observe all relevant information in the vehicle manual when mounting or using the product. IF YOU DO NOT UNDERSTAND ANY PART OF THESE MOUNTING INSTRUCTIONS OR NEED AN EXPLANATION AS TO A SPECIFIC INSTRUCTION, DO NOT ATTEMPT TO INSTALL THIS PRODUCT WITHOUT CONSULTING SW-MOTECH FOR ASSISTANCE!

PREPARATION: Read the mounting instructions carefully and make sure that all parts on the parts list are available.

 **CAUTION:** Ensure that your vehicle is standing securely. Switch off the engine and remove the ignition key. Allow the engine/exhaust to cool down if necessary. Disconnect the battery when working on the electrical system. Only use proper tools and always wear safety goggles and gloves during assembly and maintenance. Have a second person help you with assembly and maintenance.

ASSEMBLY: All parts and connections removed from the vehicle must be reinstalled according to the vehicle manufacturer's specifications or replaced with parts and hardware supplied by SW-MOTECH.

 **WARNING:** Secure all threads with a medium-strength liquid threadlocker, unless otherwise specified.

 **DANGER:** Tightening torques not defined by SW-MOTECH must be obtained from the vehicle manufacturer or a certified motorbike workshop.

FUNCTIONAL CHECK: After mounting the product, ensure that no moving parts are obstructed and that the function of the vehicle is not impeded. Cables and hoses must not rub against each other and/or be hindered in any way.

 **WARNING:** Carry out a comprehensive functionality check before you start to drive. Check the tightening torque of all connections and the tight fit of the product after the first 50 km and then at regular intervals. Mounted accessories can change the handling and stability of the vehicle.



SW-MOTECH GmbH & Co. KG
Ernteweg 7-10
35282 Rauschenberg
Germany



 info@sw-motech.com
 www.sw-motech.com

LEGEND OVERVIEW - READ AND KEEP MOUNTING INSTRUCTIONS!



Take note of the symbols and what they mean in the ASSEMBLY section. If the term OEM appears in the ASSEMBLY section, the vehicle manufacturer's specifications must be observed and applied.



If you have any questions, please don't hesitate to contact our Customer Service team or our distributors. You can find our telephone number and a list of our distributors in our online shop:

www.sw-motech.com



Use thread locker: Indicates that a thread must be coated with liquid thread locker. H (HIGH): high strength; M (MEDIUM): medium strength; L (LOW): low strength.



Tighten/note the tightening torque information:

Indicates the tightening torque of a part specified by SW-MOTECH or the vehicle manufacturer (OEM).

PARTS LIST - READ AND KEEP MOUNTING INSTRUCTIONS!

2

1



NSW.07.602.001.11

 **1/1**

2



M6 x 40; DIN 912
SC.ST.06.040.01.912.088

 **2/2**

3



ø 6.4; DIN 9021
US.ST.064.01.9021

 **2/2**

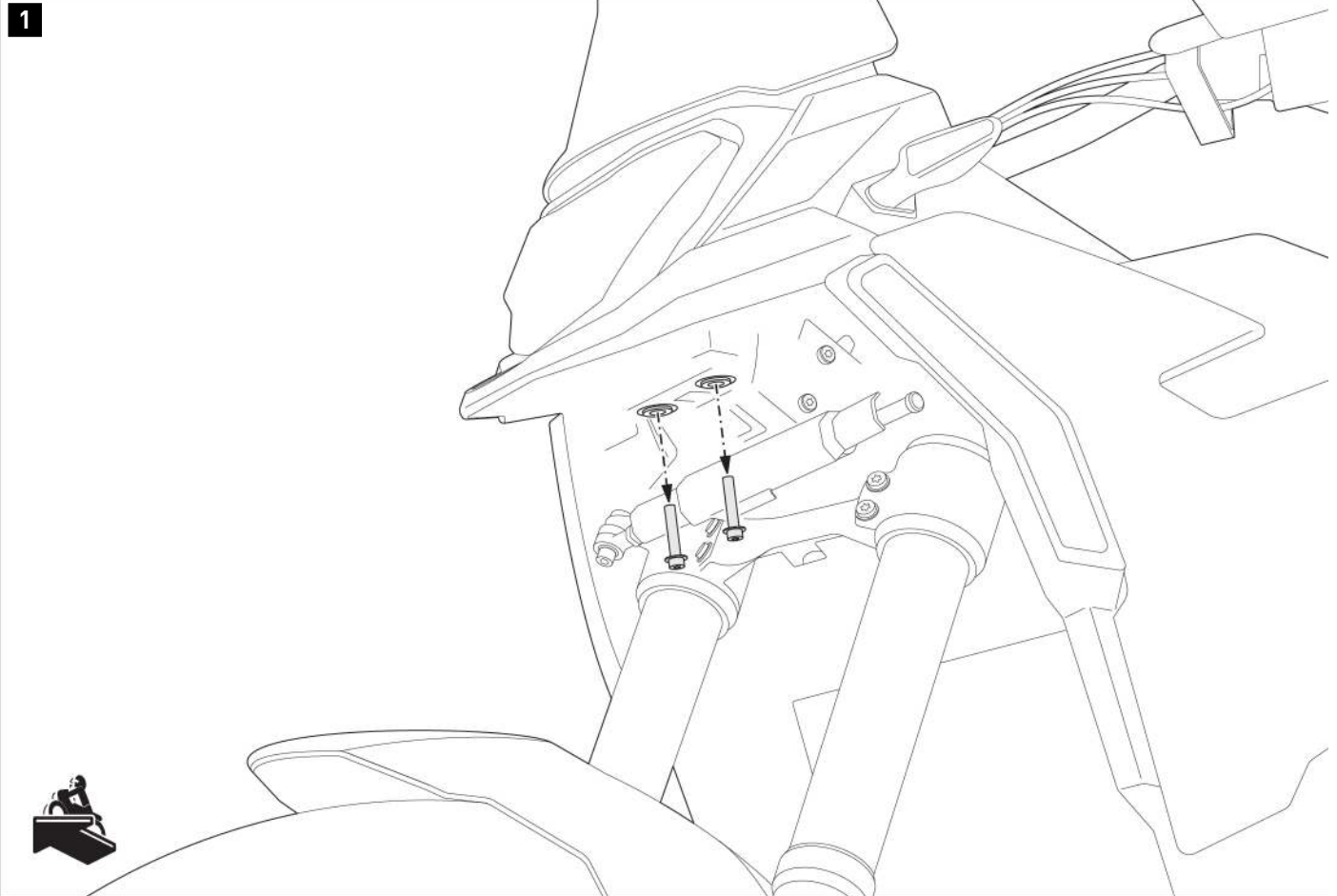

▲ WARNING: Always wear eye and hand protection!
▲ WARNING: Always use the proper tools!

Remove the original screws.



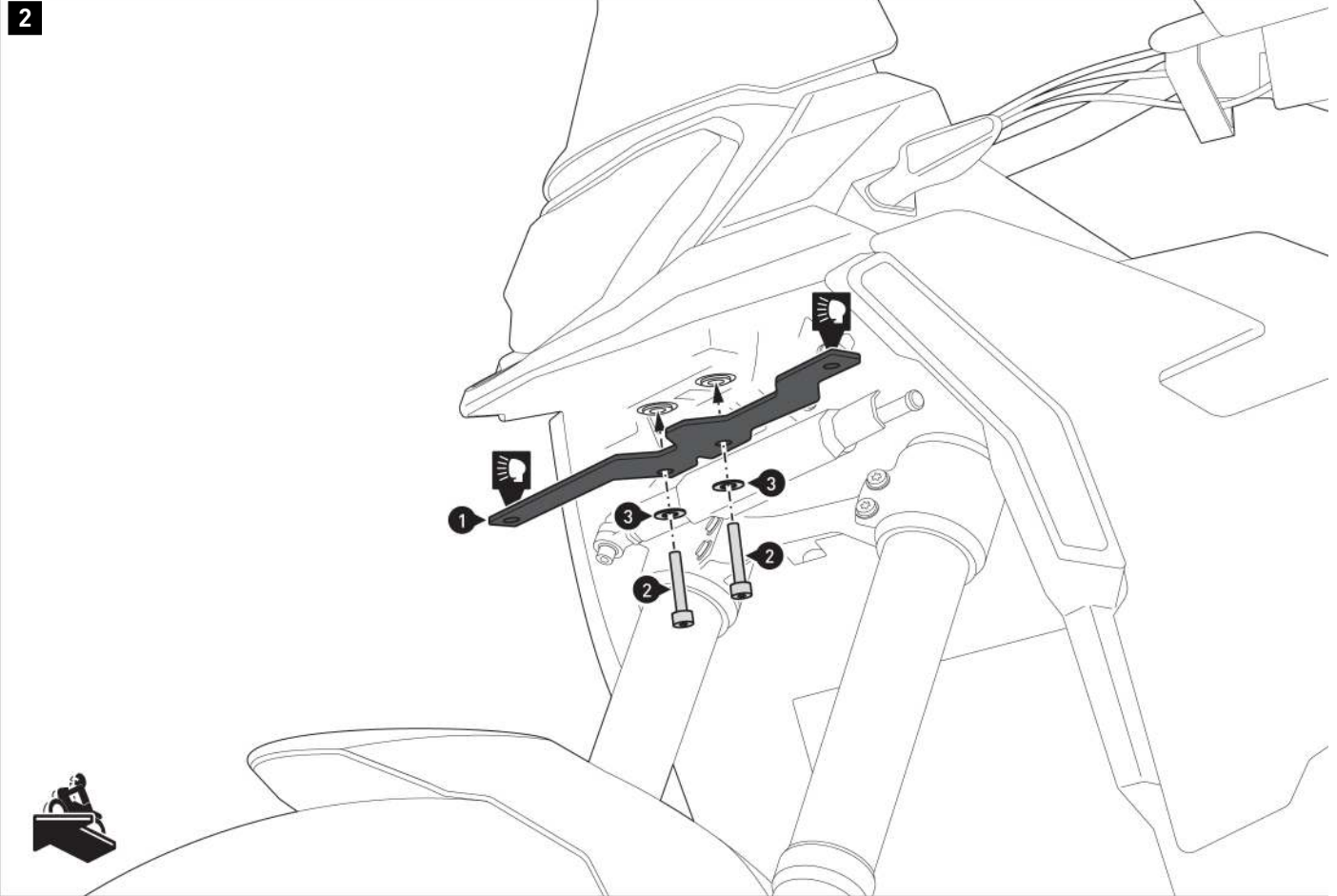

Screw the headlight mount (1) onto the vehicle.

▲ WARNING: Use liquid threadlocker!

Tighten the screws (2) according to the manufacturer's instructions.

Screw your SW-MOTECH headlights onto the headlight mount (1) in the position shown.

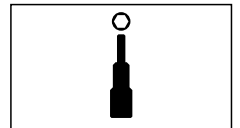
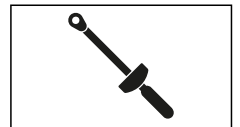

PRODUCT-SPECIFIC NOTES

⚠ NOTE: *Observe the country-specific regulations for the registration/operation of your vehicle or applicable TÜV regulations. After assembly, have parts that are subject to registration entered in the vehicle documents by your test centre.*

Art.-Nr. / Item No.: **NSW.00.490.10101**

Revision: **02** · Datum / Date: **02 - 2023**

EVO Fernscheinwerfer

EVO high beam lights

DEUTSCH - Vielen Dank, dass Sie sich für dieses Premium-Produkt von SW-MOTECH entschieden haben. Bitte besuchen Sie unseren Webshop für weitere Informationen wie Modellzuweisungen und PDF-Anbauanleitung. Erforderliche Dokumente (z. B. ABE) stehen als Download zur Verfügung.

Die Montage und/oder Wartung dieses Produkts erfordert ein gutes technisches Verständnis! Zu Ihrer eigenen Sicherheit empfiehlt SW-MOTECH, die Montage und/oder Wartung durch eine Fachwerkstatt durchführen zu lassen! SW-MOTECH übernimmt keine Haftung für Schäden, die durch eine unsachgemäße Montage und/oder Wartung verursacht wurden!

Beachten Sie alle in der Anbauanleitung angegebenen Hinweise und die für die Montage relevanten Informationen im Fahrzeughandbuch. Nichtbeachtung kann zu Schäden am Fahrzeug bzw. zur Gefährdung des Fahrers führen! Diese Anbauanleitung ist nach unserem derzeitigen Kenntnisstand verfasst worden. Rechtliche Ansprüche auf Richtigkeit bestehen nicht.

Dieses Produkt wurde für Fahrzeuge im Werkzustand entwickelt. Die Kompatibilität mit Original-Zubehörteilen bzw. den Zubehörteilen anderer Hersteller kann nicht gewährleistet werden. Stellen Sie des Weiteren VOR Montage dieses Produkts sicher, dass sich alle beweglichen Teile (z. B. die Kette) im ursprünglichen Wartungszustand befinden. Montiertes Zubehör kann das Fahrverhalten und/oder die Stabilität Ihres Fahrzeugs verändern.

ALLGEMEINE HINWEISE

Beachten Sie die landesspezifischen Vorschriften für Zulassung/Betrieb Ihres Fahrzeugs bzw. anwendbare TÜV-Vorschriften. Lassen Sie eintragungspflichtige Teile nach Montage durch Ihre Prüfstelle in die Fahrzeugpapiere eintragen.

VORBEREITUNG: Lesen Sie die Anbauanleitung aufmerksam und stellen Sie sicher, dass alle Teile der Stückliste vorhanden sind. Achten Sie darauf, dass Ihr Fahrzeug sicher steht und nicht umfallen kann. Schalten Sie den Motor ab und ziehen Sie den Zündschlüssel. Lassen Sie ggf. den Motor/Auspuff abkühlen. Klemmen Sie bei Arbeiten an der Elektrik die Fahrzeugbatterie ab. Verwenden Sie geeignetes Werkzeug. Lassen Sie sich von einer zweiten Person helfen.

MONTAGE: Alle vom Motorrad gelösten Teile und Verbindungen sind gemäß den Fahrzeugherstellereangaben wieder zu montieren oder durch die von SW-MOTECH gelieferten Teile zu ersetzen. Sichern Sie, falls nicht anderweitig definiert, alle Gewinde mit mittelfester, flüssiger Schraubensicherung.

Alle nicht durch SW-MOTECH definierten Anzugsmoment-Vorgaben müssen beim Fahrzeughersteller oder einer Fachwerkstatt erfragt werden!

FUNKTIONSKONTROLLE: Stellen Sie nach der Montage sicher, dass alle zuvor gelösten Teile und Verbindungen wieder ordnungsgemäß montiert wurden. Achten Sie außerdem auf die uneingeschränkte Freigängigkeit und einwandfreie Funktion sämtlicher Fahrzeugteile. Kabel, Züge und Schläuche dürfen nicht scheuern und/oder geklemmt werden. Führen Sie vor Fahrtbeginn eine umfassende Funktionskontrolle durch. Überprüfen Sie nach den ersten 50 km und anschließend in regelmäßigen Abständen das Anzugsmoment aller Schraubverbindungen und den ordnungsgemäßen Sitz des Produkts.

PRODUKTSPEZIFISCHE HINWEISE

ACHTUNG: Da es sich um ein universell montierbares Produkt handelt, können wir keine fahrzeugspezifischen Montagehinweise oder landesspezifischen Bestimmungen mit dieser Anleitung zur Verfügung stellen! Überlassen Sie aus diesem Grund die Montage, Verkabelung und Ausrichtung von diesem Produkts einer Fachwerkstatt!

ACHTUNG: Bei gleichzeitiger Nutzung der Scheinwerfer und mehreren Verbrauchern kann sich die Batterie schnell entleeren (auch beim Fahren)!

ENGLISH - Thank you for choosing this premium product from SW-MOTECH. Please visit our webshop for additional information, such as application charts and PDF mounting instructions. Any other documents that may be required (e.g. ABE certifications), are also available for download at our webshop.

Installation and/or maintenance of this product require good technical understanding! For your own safety SW-MOTECH recommends having installation and/or servicing carried out by a specialist workshop! SW-MOTECH assumes no liability for damage caused by improper installation and/or maintenance work!

Carefully follow all the directions given in the mounting instructions and pay attention to all relevant information in the vehicle manual during assembly. Nonconformance can lead to vehicle damage or even endanger the driver! These mounting instructions are written based on our current state of knowledge. Legal requirements for accuracy do not exist.

This product was developed for vehicles in their factory setting. Compatibility with original accessory parts or other manufacturers' accessory parts is not guaranteed. Furthermore, BEFORE installing this product, make sure that all moving parts (e.g. the chain) are in the original state of maintenance. Installed accessories can change the driving behaviour and/or stability of your vehicle.

GENERAL INFORMATION

Observe the country-specific regulations concerning vehicle registration/operation as well as TÜV regulations if applicable. If required, register installed parts in the vehicle documents through an appropriate inspection authority.

PREPARATION: Read the mounting instructions carefully and make sure that all items of the parts list are included. Make sure that your vehicle is parked safely and cannot fall over. Turn off the engine and remove the ignition key. Let the motor/exhaust cool off if necessary. Disconnect the vehicle battery when working on the electrical system. Use appropriate tools. Have another person to help you.

MOUNTING: All parts and connections removed from the vehicle must be reinstalled in accordance with the vehicle manufacturers' specifications or replaced by parts delivered by SW-MOTECH. Secure all threads, unless otherwise specified, with medium-strength liquid thread locker.

Torque specifications undefined by SW-MOTECH must be obtained from the vehicle manufacturer or by a specialist workshop!

FUNCTION CHECK: After installation make sure that all parts and connections previously removed are properly replaced. Also make sure that no moving parts are obstructed and no function of the vehicle is hindered in any way. Cables and hoses must not rub and/or be pinched. Before starting to ride, perform a comprehensive check of all functions. After the first 50 km and then at regular intervals, check the tightening torque of all screw connections and the proper fit of the product.

PRODUCT SPECIFIC INFORMATION

ATTENTION: Since this is an universally mountable product, we can not provide vehicle-specific mounting instructions or country-specific regulations with these instructions!

For this reason, leave the assembly, wiring and alignment of the product to a specialist workshop!

ATTENTION: Be careful when using multiple electrical accessories with your motorcycle at the same time! If there are too many loads on the battery it is possible to drain the battery even while driving!

Konfektionierung durch / Packed by:

Datum der Konfektionierung / Date of packaging:



SW-MOTECH GmbH & Co. KG

Ernteweg 8/10
35282 Rauschenberg
Germany

Tel. / phone + 49 (0)6425 / 8168 - 050

Fax / fax + 49 (0)6425 / 8168 - 10

info@sw-motech.com
www.sw-motech.com

STÜCKLISTE / PARTS LIST

| Schritt Step | Nr. No. | Art.-Nr. / Bezeichnung * Item No. / Description * | Artikel | Part | Anzahl ** Quantity ** | N-m *** |
|-----------------|------------|------------------------------------------------------|-----------------------------------|---------------------------------------|--------------------------|---------|
| 1 | (1) | NSW.00.490.500.05 | Scheinwerfer | Light | 2 /2 | |
| | (2) | NSW.00.490.500.03 | Anbauadapter | Mounting Adapter | 2 /2 | |
| | (3) | M4 x 12; DIN 912 | Innensechskantschraube; Edelstahl | Hexagon Socket Screw; stainless steel | 2 /2 | 3 |
| | (4) | M8 x 20; ISO 7380 | Linsenkopfschraube; schwarz | Lenshead Screw; black | 2 /2 | 20 |
| | (5) | d 8,4; DIN 125 | Unterlegscheibe; schwarz | Washer; black | 2 /2 | |
| | (6) | d 8,4; DIN 6797 | Sperrzahnscheibe; schwarz | Tooth Lock Washer; black | 2 /2 | |
| 2 | (7) | NSW.00.490.500.07 | Kabelbaum | Cable Harness | 1 /1 | |
| | (8) | | Abzweigverbinder | Branch Connector | 1 /1 | |
| | (9) | 4,8 x 145 | Kabelbinder | Cable Tie | 5 /5 | |
| | (10) | NSW.00.490.500.08 | Schalter | Switch | 1 /1 | |
| | (11) | 35 x 18 x 3 | Gummieinlage | Rubber Inlay | 1 /1 | |
| | (12) | 25 x 18 x 2 | Gummieinlage | Rubber Inlay | 1 /1 | |
| | | | | | | |
| | | | | | | |
| | | | | | | |
| | | | | | | |
| | | | | | | |
| | | | | | | |

| 8.8 | Regelgewinde / Coarse Thread Ø | | | | | | N-m | M4 | M5 | M6 | M8 | M10 | M12 | 10.9 | Regelgewinde / Coarse Thread Ø | | | | | | N-m | M4 | M5 | M6 | M8 | M10 | M12 |
|-----|--------------------------------|-----|-----|-----|----|----|-----|----|----|----|----|-----|-----|------|--------------------------------|-------------------------------|-----|-----|----|----|-----|----|----|----|----|-----|-----|
| | Stahl FK 8.8 / Steel CL 8.8 | 2,8 | 5,5 | 9,6 | 23 | 46 | | | | | | | | | 79 | Stahl FK 10.9 / Steel CL 10.9 | 4,1 | 8,1 | 14 | 34 | | | | | | | |

* Alle Maßangaben in Millimeter. - ** Der zweite Wert gibt die Gesamtanzahl des jew. Artikels in der Lieferung an.
 *** **Keine Anzugsmomentvorgabe: Verwenden Sie das vom Fzg.-Hersteller definierte Anzugsmoment!** Das Standard-Anzugsmoment der Tabelle kann verwendet werden, wenn es den Fzg.-Hersteller-Vorgaben entspricht.

* All measurements in millimeters. - ** The second number indicates the total quantity of the part in the delivery.
 *** **No torque specifications: Use the torque defined by vehicle manufacturer!** The standard torque in this table can be used as long as it is within the vehicle manufacturer's specifications.

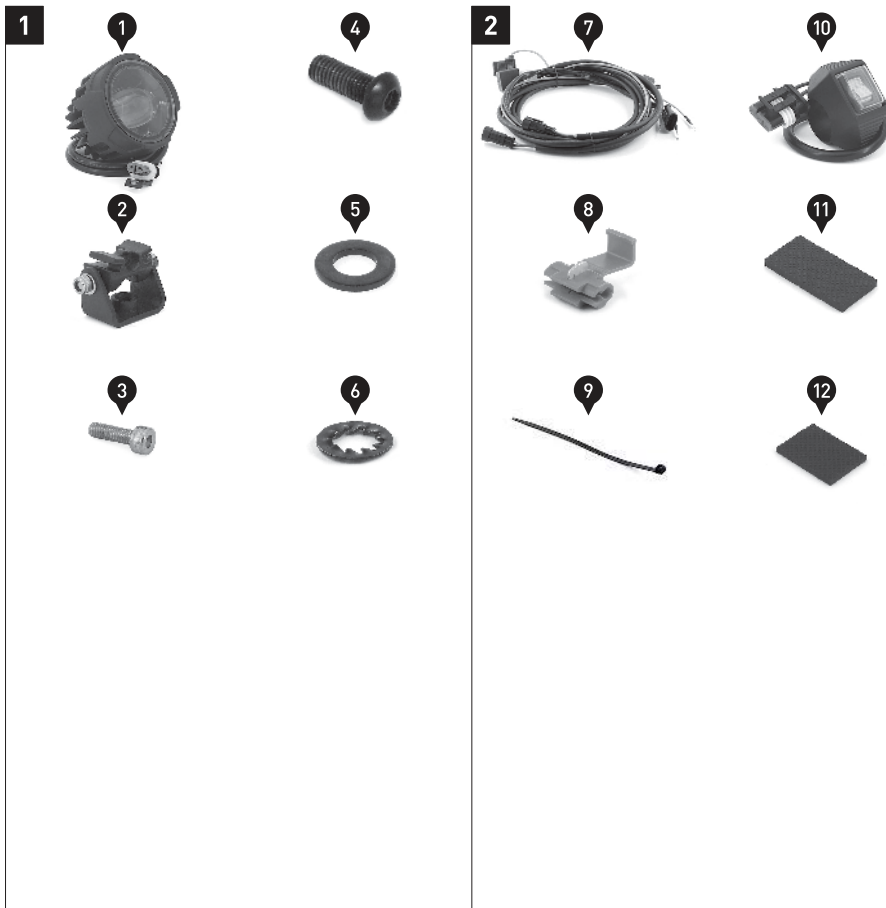

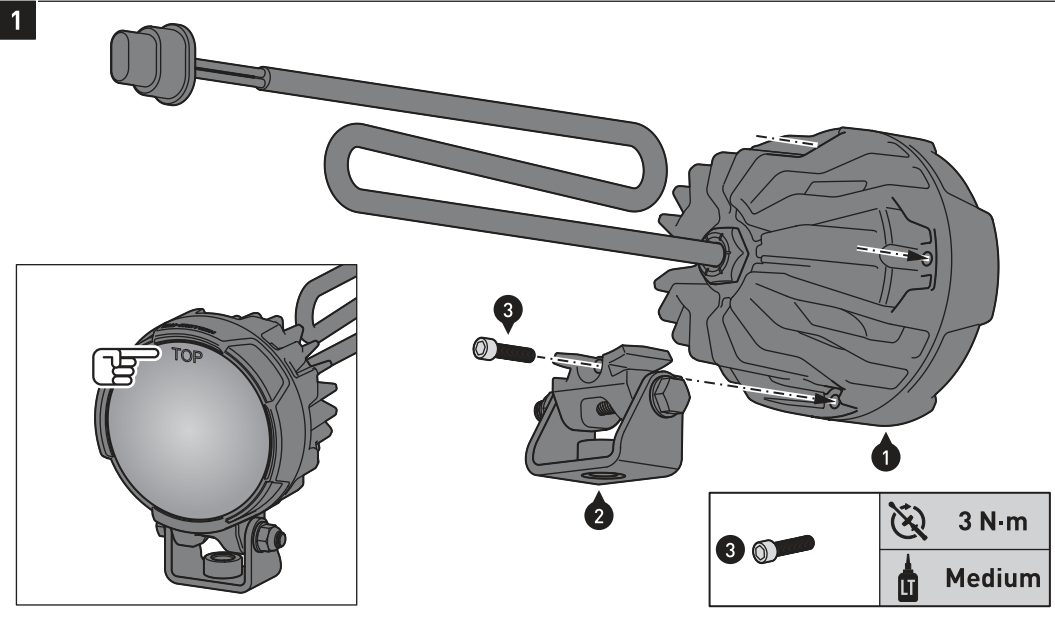

Die Scheinwerfer (1) können in hängender, stehender oder seitlicher Position verbaut werden. **ACHTUNG: Beachten Sie, dass die „TOP“-Markierung aufgrund der Reflektorkrümmung immer oben stehen muss.** Montieren Sie die Anbauadapter (2) an einem der Montagepunkte, wie in der Zeichnung gezeigt. **ACHTUNG: Verwenden Sie flüssige Schraubensicherung!** Ziehen Sie die Schrauben wie in der Stückliste vorgegeben an.

The lights (1) can be mounted in hanging, standing or lateral position. **ATTENTION: Due to the reflector angle make sure that the "TOP" mark is on top.** Attach the mounting adapters (2) to one of the mounting points, as shown in the drawing. **ATTENTION: Use liquid thread locker!** Tighten the screw as specified in the parts list.

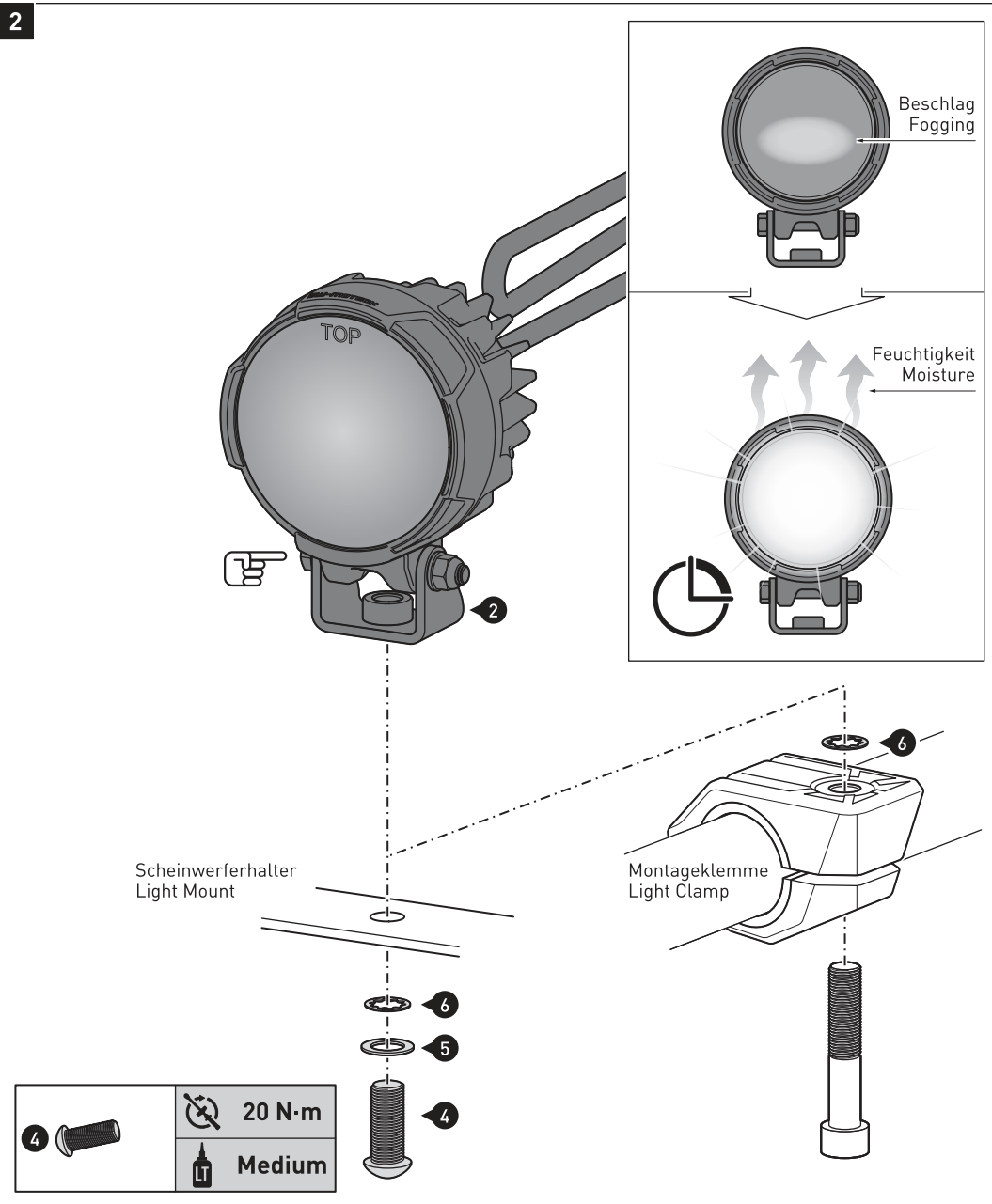

Verschrauben Sie die Anbauadapter (2) an Ihrem Scheinwerferhalter bzw. Montageklemme von SW-MOTECH, wie in der Zeichnung gezeigt. **ACHTUNG: Verwenden Sie flüssige Schraubensicherung!** Ziehen Sie die Schrauben (4) wie in der Stückliste vorgegeben an. Ziehen Sie die Schrauben der Montageklammern wie in deren Anbauanleitung vorgegeben an. Der Neigungswinkel der Scheinwerfer (1) kann über die markierte Schraube des Anbauadapters (2) eingestellt werden. *HINWEIS: Im Bereich der Linse kann es unter bestimmten Umständen zu einem Beschlag kommen. Dieser Beschlag beeinträchtigt NICHT die Funktion des Scheinwerfers und verschwindet während des Betriebes.*

Attach the mounting adapters (2) to your light mount or light clamp by SW-MOTECH, as shown in the drawing. **ATTENTION: Use liquid thread locker!** Tighten the screw (4) as specified in the parts list. Tighten the screws of the light clamps as specified in their mounting instructions. Adjust the inclination angle of the lights (1) by the marked screws of the mounting adapter (2). *NOTE: Fogging may occur in the lens area under certain circumstances. The fogging does NOT affect the function of the lights and disappears during operation.*

3

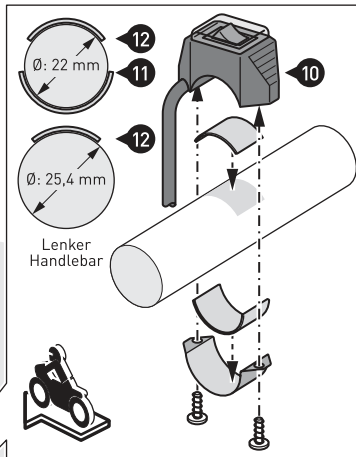
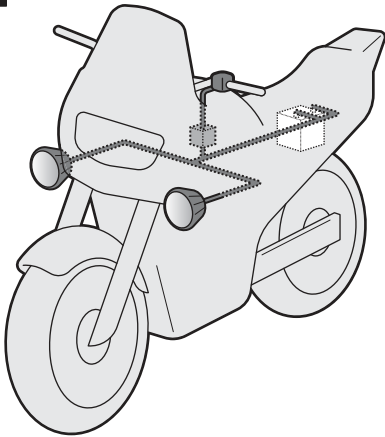

ACHTUNG: Führen Sie die Verkabelung mit äußerster Vorsicht aus! Überlassen Sie die Verkabelung im Zweifelsfall einer Fachwerkstatt!
Verhindern Sie das Aufscheuern des Kabels! Achten Sie bei der Verlegung des Kabels darauf, dass der volle Lenkeinschlag ohne Behinderung möglich ist! Achten Sie unbedingt darauf, dass der Kabelbaum WEDER geklemmt wird noch Kontakt zu heißen und/oder beweglichen Teilen hat!

ACHTUNG: Achten Sie auf eine korrekte Kabelisolierung! Sollte eine Beschädigung vorliegen, tauschen Sie diese Komponente umgehend aus!

Klemmen Sie die Fahrzeugbatterie ab.

Verbinden Sie das WEISSE Kabel des Kabelbaums (7) mit dem Pluspol der Fahrzeugbatterie.

Verbinden Sie anschließend das SCHWARZE Kabel des Kabelbaums (7) mit dem Minuspol der Batterie.

Befestigen Sie den Kabelbaum (7) mit den Kabelbindern (9) am Kabelbaum des Fahrzeugs.

Nutzen Sie den Abzweigverbinder (8), um den Kabelbaum (7) mit dem geschalteten Pluspol zu verbinden. Dazu einfach das Kabel durch den Abzweigverbinder (8) führen und den Kunststoffbügel schließen, wie in der unteren Detailzeichnung gezeigt.

ACHTUNG: Achten Sie bei der Montage auf eine wassergeschützte und sichere Befestigung des Relais (mit Kabelbinder befestigen).

ATTENTION: Please mount with extreme caution! In case of doubt have the wiring carried out by a specialist workshop! Avoid short-circuits! Prevent cable rubbing! Ensure that full movement of the handlebars is still possible! The cable harness MUST NOT be under tension or have contact with hot and/or moving parts!

ATTENTION: Make sure the electric cable is not damaged! If the cable is damaged, replace the component immediately!

Disconnect the battery.

Mount the WHITE cable of the cable harness (7) to the positive pole of the battery.

Then mount the BLACK cable of the cable harness (7) to the negative pole of the battery.

Attach the cable harness (7) with the cable ties (9) to the cable harness of the vehicle.

Use the branch connector (8) to connect the cable harness (7) to the switched positive pole. Connect the cable with the branch connector (8), then close the snap fastener to secure the connection as shown in the lower detail drawing.

ATTENTION: Make sure to attach the relay securely and in an area that will not be affected by water (attach it with a cable tie).

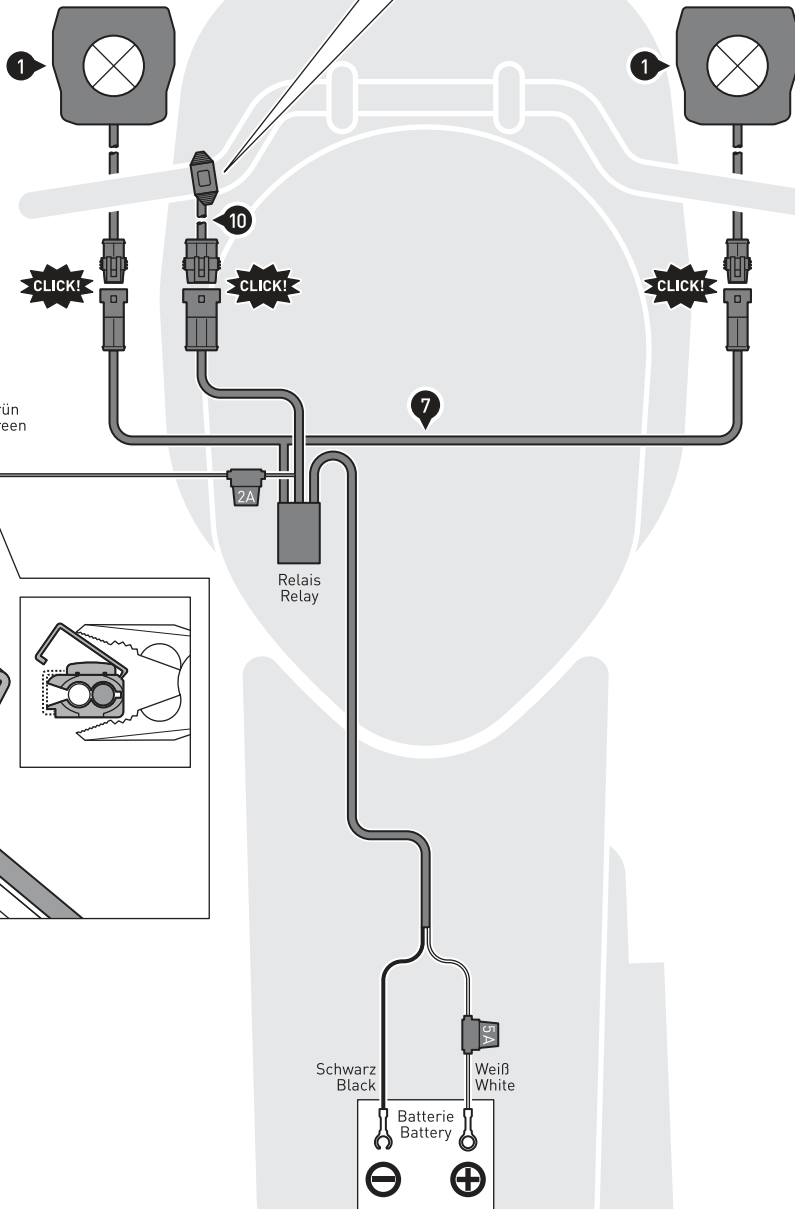

Geschalteter Pluspol des Fahrzeugs (über Zündung).
Grün Green
Switched positiv pole of the vehicle (at ignition).

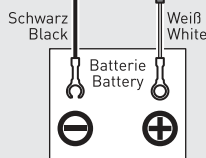

⚠ ACHTUNG / ATTENTION

Führen Sie nach der Montage eine umfassende Funktionskontrolle der Lichtanlage durch!

After mounting, perform a comprehensive check of the lighting system!

! Beispiellabbildung!
Example shown!